

Automatic Level Control (ALC) Filter Amplifier



WORK Microwave now offers ALC filter amplifiers as a stand-alone unit or as an application-specific option within its downconverters. The picture above shows the stand-alone unit.

The input of this unit can be connected to the IF output of the downconverter.

The picture below shows a block diagram of the application-specific ALC filter amplifier. The signal is bandpass filtered on the input as well as on the output. Both bandpass filters are identical.

The pictures on the next page show typical amplitude frequency responses of such filters. The overall filter characteristic of the complete unit results from a series connection of the two identical filters, doubling all attenuation values in dB, which means that e.g. a stop-band suppression of 50 dB for one filter results in an overall stop-band suppression for the complete unit of about 100 dB (for the same frequency point).

In between these filters a variable gain stage allows adjustment of the signal level. A small portion of the output signal level is coupled to an RMS detector.

A digitally implemented control algorithm using a microprocessor allows operators to select a specified output level and keeps the output level constant, even if the input signal varies within the allowed level range. The operational parameters of the ALC amplifier can be configured from the front panel processor as well as remotely. Monitoring of the ALC amplifier is also possible from the front panel processor as well as remotely. Besides the main ALC output, an ALC monitor output is available on the rear panel.

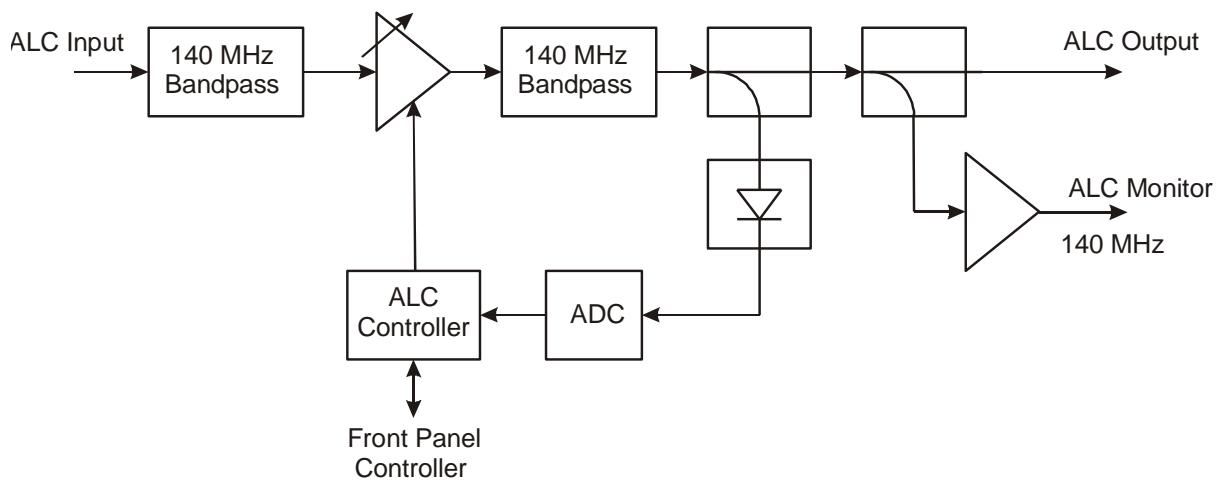

Automatic Level Control (ALC) Filter Amplifier

IF Input:	Center Frequency: 140 MHz Frequency Range: 80 ... 200 MHz Signal Level: -50 ... -20 dBm Return Loss: > 18 dB (within filter passband bandwidth) Connector: SMA female Impedance: 50 Ω
IF Output:	Center Frequency: 140 MHz Bandwidth: 34 MHz or 41 MHz or 54 MHz or 75 MHz or 110 MHz Signal Level: -5 dBm ... 10 dBm (adjustable, 0.1 dB step size) Return Loss: > 18 dB (within filter passband bandwidth) Connector: SMA female Impedance: 50 Ω
IF Monitor Output:	Signal similar to IF Output Signal Level: 20 dB lower than IF Output Return Loss: > 20 dB Connector: SMA female Impedance: 50 Ω
Transfer Characteristics:	Gain: 15 ... 60 dB (automatically or manual adjustable, 0.1 dB step size) Group delay: < 0.5 ns / 25 kHz within 54 MHz bandwidth Bandwidth: 54 MHz (3 dB) Frequency Range: 113 ... 167 MHz (3 dB)
Interrmodulation (3rd Order):	< -55 dBc, (Pout: 2 x +4 dBm)
ALC Control:	Fast attack for required gain adjustment > configurable value (0.1 ... 5 dB) with configurable time constant up to 1000 s. Gradual adjustment for required gain adjustment < configurable value (0.1 ... 5 dB) with configurable time constant up to 1000 s Control cycle approx. 100 ms. No interruption of the signal during adjustment.
Monitoring and Control Interfaces:	Ethernet/IP (10 or 100 Mbps, auto sensing) RS232 or RS422/RS485 (Connectors DSUB09 female) (configurable)
Alarm Interface:	Two potential free contacts (DPDT, Connector DSUB09 female)
Temperature Range:	-25 °C ... 60 °C operating the LCD display is operational: -20 °C ... 60 °C -30 °C ... 80 °C storage
Relative Humidity:	< 95 % non condensing
User Interface:	LCD, 2 x 40 characters, 4 cursor keys, 4 function keys
Mains Power Input:	100 ... 240 V AC nominal, 90...264 V AC max, 50...60 Hz
Mains Power Consumption:	Max: 16 VA / 8 W Typ.: 12 VA / 5 W
Mains Power Input Connector:	IEC C14
Mains Fuse:	2.0 A time-lag fuse
Dimension and Weight:	483 x 44 x 270 mm ³ (WxHxD), 1 RU (19") approx. 3 kg

Specifications are subject to change

Order Information: **ALC-[IF Frequency in MHz]-[Filter BW in MHz]**

Examples:

- ALC-140-34**
- ALC-140-41**
- ALC-140-54**
- ALC-140-75**
- ALC-140-110**